

SHARKBITE®

PEX INSTALLATION INSTRUCTIONS



Table of Contents

| | |
|---|-----------|
| Introduction..... | 3 |
| Features and Benefits of SharkBite® Tubing | |
| Features and Benefits of SharkBite® push-fittings | |
| Features and Benefits of Clamp/Barb Systems | |
| Types of Plumbing Systems..... | 4 |
| Truck and Brand Systems | |
| Manifold Systems | |
| Combination Systems | |
| Home-Run Systems | |
| Making a SharkBite® Push Fitting Connection..... | 5 |
| Connection with SharkBite® PEX | |
| Making a SharkBite® Clamp/Barb Fitting Connection..... | 6 |
| Connection with Clamp System | |
| Calibration of Clamp Tool | |
| Removing a Clamp | |
| Connection with Crimp System | |
| Dos and Don'ts for SharkBite® PEX Tubing..... | 9 |
| Cross Linking Methods..... | 10 |
| Installation Tips..... | 10 |
| Proper Support | |
| Concrete Installation | |
| Technical Data..... | 10 |
| SharkBite® PEX Tubing Marking Certifications..... | 11 |
| Maximum Working Pressure | |
| Thermal Expansion | |
| Tubing Dimensions, Bend Radius and Fluid Capacity | |
| Pressure Loss Data | |
| Policies and Warranty..... | 12 |



Combine SharkBite® fittings, manifolds and valves with SharkBite® PEX for the only Total Rough-In Solution™ Connection System – and (using push-fittings) the fastest way to plumb any residential or commercial project. Ask for the complete product line brochure or learn more at www.sharkbite.com

Introduction

The purpose of this guide is to familiarize plumbing professionals with the SharkBite® Connection System, and the recommended method of installing SharkBite® PEX tubing. SharkBite® PEX tubing can be used with SharkBite® push-fittings, SharkBite® barbed fittings, SharkBite® manifolds, and SharkBite® valves.

SharkBite® PEX is an excellent tubing product for plumbing, radiant and hydronic systems, offering many advantages over traditional rigid pipe. The combination of SharkBite® push-fit fittings, manifolds, valves and PEX tubing is the **FASTEST** way to plumb any residential or commercial project. If **COST** of **MATERIAL** takes priority, SharkBite® barb fittings may be used with clamp or crimp rings. In addition, a variety of valves and manifolds with SharkBite barb connectors are included in the SharkBite® Connection System line, making it the only Total Rough-In Solution™.

{ Features and Benefits of Sharkbite® PEX Tubing }

Flexible:

- **Easy to install and service.**

Quieter:

- **Minimizes noise caused by water hammer.**

Resists corrosion and scale buildup:

- **Improves the performance of the plumbing system.**

Fewer fittings required:

- **Reduces total installation cost.**

Fewer joints:

- **Reduces the chances of call backs.**

Pressure test immediately:

- **No waiting for glue to dry or joints to cool.**

{ Features and Benefits of Sharkbite® Push-Fittings }

Instant push-fit connection for increased ease-of-use:

- **No soldering, clamps, unions or glue required.**

Fittings certified to 200 PSI and 200°F (93°C):

- **Proven durability and quality.**

Fits copper tubing, CTS CPVC and PEX:

- **Connects all three types in any combination.**

Integral tube liner for PEX installations:

- **Integrated design means no loose components, ensures secure, reliable connection.**

Design certified and agency listed:

- **Inspector friendly, peace of mind!**

Compact, robust DZR brass body:

- **Foundation of a strong, corrosion resistant, durable fitting.**

Design certified to ANSI/NSF-61 and ASSE 1061 product standard for use in potable water and hydronic heating water distribution:

- **Quality engineered and manufactured.**

Approved to be used underground and behind walls without access panels. Designed for radiant and hydronic heating as well as potable water distribution.

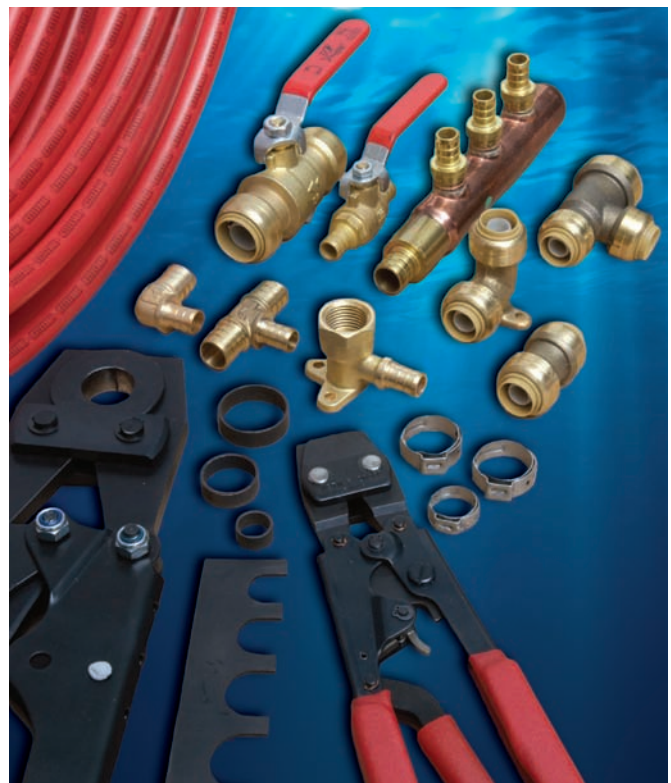

{ Features and Benefits of Sharkbite® Barb Fittings }

Broad line of fittings and manifolds:

- **A typical barb system offers the lowest material cost.**

{ Features and Benefits of Sharkbite® Valves }

Line includes ball, regulator, and thermostatic mixing valves:

- **Push-fit (integral & union type) or barb connectors.**

{ Features and Benefits of Sharkbite® PEX Tools }

Clamp Ring Tool (one clamping tool for all size clamp rings):

- **Reduced equipment cost and saves installation time.**
- **One hand operation (leaves a hand free to position the clamp ring).**

Crimp Ring System (Heavy-duty components with adjustment tools and case):

- **Includes 5 interchangeable jaws and go/no-go gauge.**

Plumbing Systems

The **SharkBite® Connection System** offers the only Total Rough-in Solution™, including a full line of valves, push-fittings, PEX tubing and traditional PEX components and tools. The SharkBite® system offers three options for a PEX tubing installation – Trunk & Branch, Manifold, or a Combination system – as described in the diagrams below.

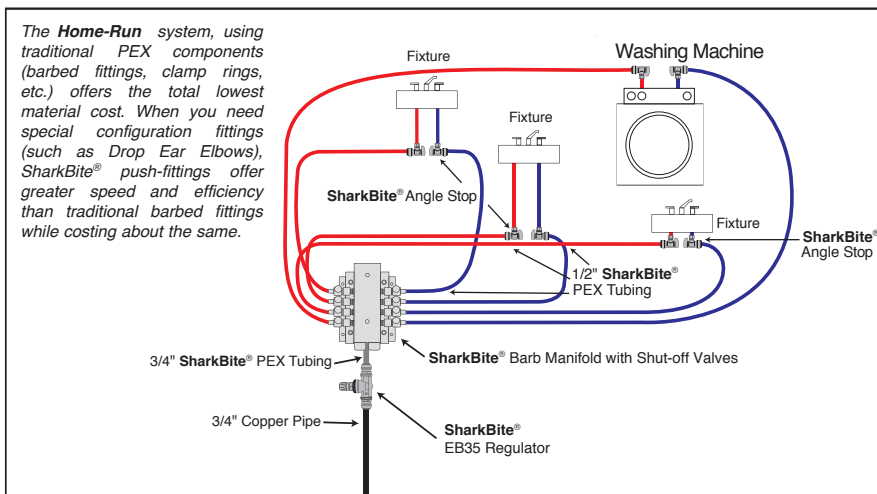
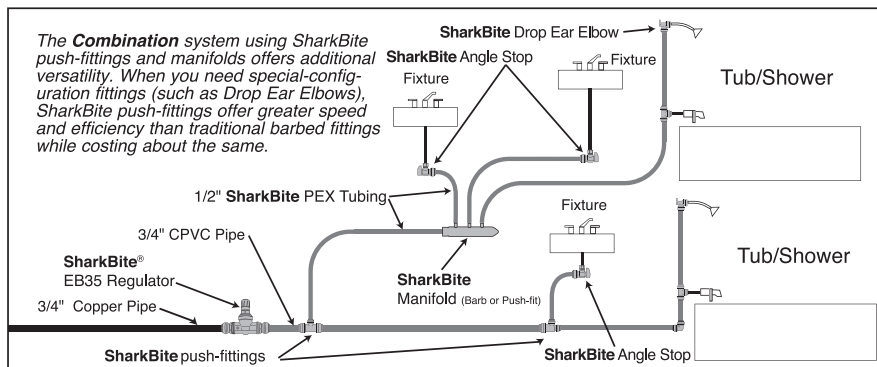
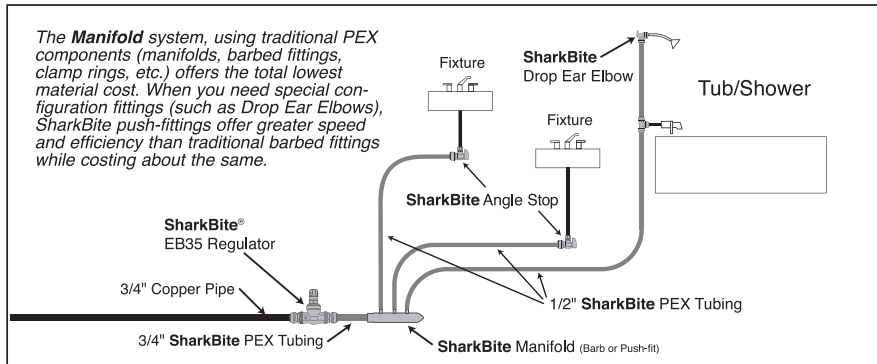
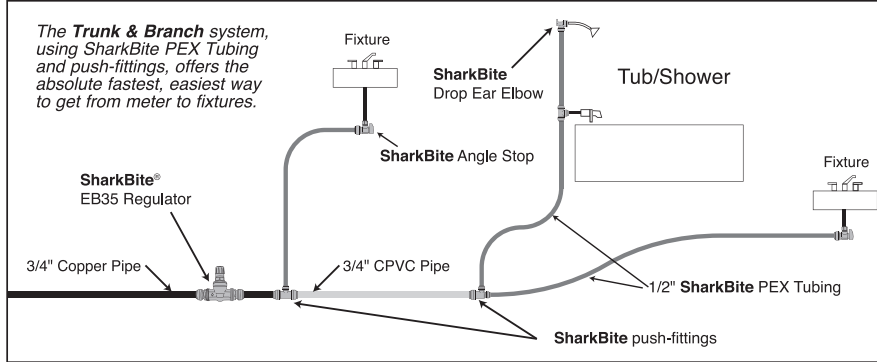

Making a SharkBite® Push-Fitting Connection

The combination of **SharkBite®** push-fittings and PEX tubing offers the fastest, easiest installation from meter to fixture.



Step 1. Use plastic tubing cutters to cut the tubing between the pointed ends of the repeating 1" SharkBite® imprint pattern. The pattern provides a visual aid to determine if the tube has been inserted all the way into the fitting. Ensure the tube is cut square. A square cut end allows the tubing to be inserted all the way into the fitting. Ensure the tube has no rough edges, cuts or abrasions (rough edges, cuts or abrasions may damage the O-ring and cause the fitting to leak).



Step 2. SharkBite® push-fittings come with integral tube support liners. Ensure that the support liner is in place. The liner reinforces the wall of the PEX tubing to help prevent collapse of the tubing wall.



Step 3. Insert the tube into the fitting until the tube reaches the tube stop. Make sure the pointed end of the SharkBite® pattern is even with the end of the release collar. Only when the tube reaches the tube stop has a secure joint been created.



Note: Install SharkBite® push-fittings at least 1" apart to enable disassembly of the joint.

Making a SharkBite® Clamp/Barb Connection

The use of traditional PEX components (manifolds, barbed fittings, clamp or crimp rings, etc.) offers the total lowest material cost.



Step 1. Use plastic tubing cutters to cut the tubing to length, making sure that you have a good square cut. A rough or uneven cut will result in a weakened joint.



Step 2. Slide the correct size clamp ring over the tube and approximately 2" past the end of the tubing.



Step 3. Push the tubing onto the barbed fitting until it touches the fitting shoulder. Position the clamp ring 1/8"-1/4" from the end of the tube. This distance ensures that the clamp ring is positioned directly over the barbs on the fitting.

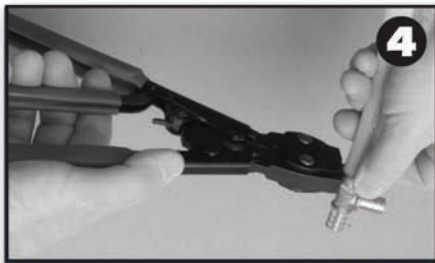

Step 4. Position the open jaws of the clamp tool over the raised tabs of the clamp ring and squeeze.

One clamp tool fits all size clamp rings. It can be operated with one hand, leaving the other hand free to hold the clamp ring in position. The tool cannot be removed until the clamp ring is fully compressed. A properly calibrated clamp tool eliminates the necessity to check each fitting ring with a go/no-go gauge.



Step 5. Verify the connection is secure by visually checking the clamp tab.

Check Calibration of Clamp Tool

Always check the Clamp Tool with the calibration gauge before the first and after the last crimp on each job site.

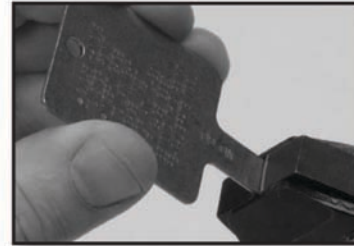
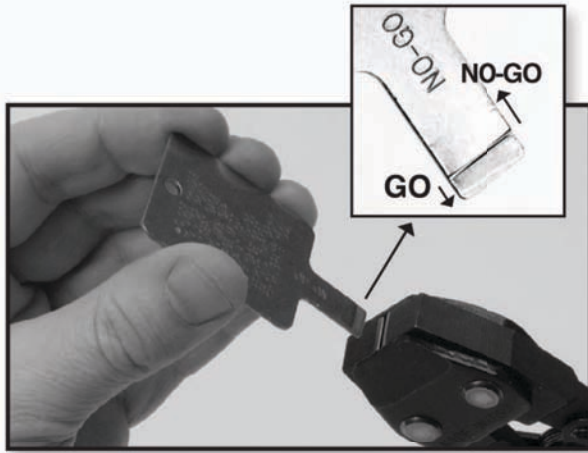

1. Close the Clamp Tool handles to the stop point and insert gauge into jaw gap

2. Gauge must stop at the NO-GO line in order to make proper connections

Calibrating the Clamp Tool

If the gauge goes into the jaws beyond the GO portion, the Clamp Tool should be recalibrated following these steps.

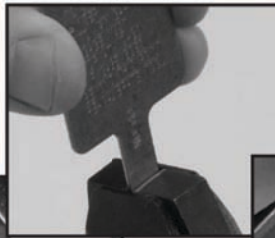
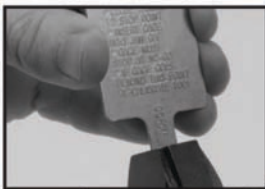

1. Place GO portion of gage into jaw gap

2. Loosen locking nut



3. Adjust clamp tool jaws by rotating the eccentric stud counter-clockwise until jaws contact gauge. Re-tighten the locking nut.

WARNING

Tools out of calibration may not make good long-term connections and can result in leaks developing over time.

Removal of a Clamp or Complete Connection

Place a flat-bladed screw driver under the clamp tab and pry up to unlock. Then using a clamp removal tool or pliers grab onto the tab and pull free.



Note: The previously clamped section of SharkBite® tubing should be cut off prior to making a new connection.

Making a SharkBite® Crimp/Barb Connection

The use of traditional PEX components (manifolds, barbed fittings, clamp or crimp rings, etc.) offers the total lowest material cost.



Step 1. Use plastic tubing cutters to cut the tubing to length, making sure that you have a good square cut. A rough or uneven cut will result in a weakened joint.



Step 2. Slide the correct size crimp ring over the tubing and approximately 2" past the end of the tubing.



Step 3. Push the tubing onto the barbed fitting until it touches the fitting shoulder. Position the crimp ring 1/8"-1/4" from the end of the tube. This distance ensures that the clamp ring is positioned directly over the barbs on the fitting.



Step 4. Position the open jaws of the crimp tool over the crimp ring and squeeze. The jaws are interchangeable, and include sizes for 3/8", 1/2", 5/8", 3/4" and 1" crimp rings.

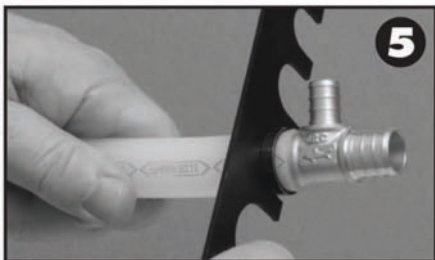

Step 5. Verify that the connection is secure by using the go/no-go gauge. The gauge slot that corresponds to the crimp ring size should easily slide onto the compressed crimp ring.

Dos and Don'ts for SharkBite® PEX Tubing

For potable water and hydronic distribution

{ Dos }

- **Do** use SharkBite® PEX tubing for hot and cold water distribution only.
- **Do** install SharkBite® PEX tubing to the appropriate plumbing code.
- **Do** pressure test the system upon completion.
- **Do** keep hot & cold lines separate.
- **Do** use only fittings and accessories that have been tested and approved for the SharkBite® PEX Connection System.
- **Do** leave extra tubing at both ends of run to make connections easier.
- **Do** ensure the tubing is supported properly to prevent undue stress, strain, thermal expansion and contraction.
- **Do** protect the SharkBite® PEX tubing from damage, both before and during the construction process.
- **Do** use SharkBite® tube liner with SharkBite® Fittings and SharkBite® PEX joint. (exception - 1/4" fittings)

{ Don'ts }

- **Do not** use sharp instruments to open the SharkBite® PEX packaging, you may damage the pipe.
- **Do not** use with natural gas, propane, fuel oil or any other fluid, chemical or product. SharkBite® PEX tubing (non oxygen barrier) is for use *with potable water only* and is not approved or intended for any other use.
- **Do not** freeze. SharkBite® tubing is freeze-resistant, but not freeze-proof. Pipe embedded in concrete that is subjected to freezing conditions will likely damage both the concrete and the pipe. Tubing that is not embedded and frozen may damage joints or manifolds. Be sure to carefully pressure test, inspect and repair systems that have been subjected to a freeze prior to returning them to normal operation.
- **Do not** pressure test with water in freezing conditions.
- **Do not** store or install where tubing will be exposed to direct or indirect ultraviolet light (i.e. sunlight).
- **Do not** expose the tubing to direct flame. Do not install tubing near extreme heat.
- **Do not** use in excessive operating conditions inconsistent with pressure ratings that appear on tubing and applicable standards.
- **Do not** subject tubing to prolonged exposure to free chlorine concentrations greater than 4 ppm.
- **Do not** use in contaminated soils.
- **Do not** expose to materials that affect the basic properties of cross-linked polyethylene, brass, or copper. Avoid contact with adhesives.
- **Do not** use with other fitting systems.
- **Do not** install through metal studs or concrete without using a protective sleeve.
- **Do not** install pipe that has defects such as: gouges, cuts, deep scratches, kinks, evidence of grease, tar or any chemical, exposure fading or discoloration.
- **Do not** use defective fittings with the pipe.
- **Do not** use supports that may collapse or cut the pipe. Supports should **not** have sharp edges which could damage the pipe.
- **Do not** use metal hangers with sharp or abrasive edges or hangers that may pinch or penetrate the pipe. Proper hangers, clamps and straps are available from your SharkBite® supplier.
- **Do not** pull pipe tight at connections. Prevent unnecessary strain on the pipe, fittings and connections with straps or clamps.
- **Do not** drag the pipe over rough terrain, rocks, or any other surface which could abrade, cut, puncture or damage the pipe wall in any way.
- **Do not** crush or kink the pipe.
- **Do not** heat kinked pipe to repair/reform. Inspect all pipe before and after installation. Damaged or kinked sections should be cut out and replaced. Keep the PEX pipe a MINIMUM of 12" vertically and 6" horizontally from sources of high heat such as recessed light fixtures, gas flue vents, heating appliances, or electric motors. Forced air heating ducts are not generally considered sources of high heat. These areas of installation should be rechecked after further construction and other mechanical systems have been installed. PEX can be run in return air plenums. Bend pipe 2" away from fitting. This prevents the fitting from being used as an anchor point.
- **Do not** exceed the minimum bend radius of the pipe. (see illustration on p.11)

Proper Support of SharkBite® PEX

SharkBite® PEX must be properly supported to protect against excessive strain. For both vertical and horizontal applications we recommend the tubing be supported every 32" between supports, leaving a little slack (1/8"-1/4") in the tube to allow for normal expansion and contraction. Always use approved PEX supports and never use a support that has sharp edges.

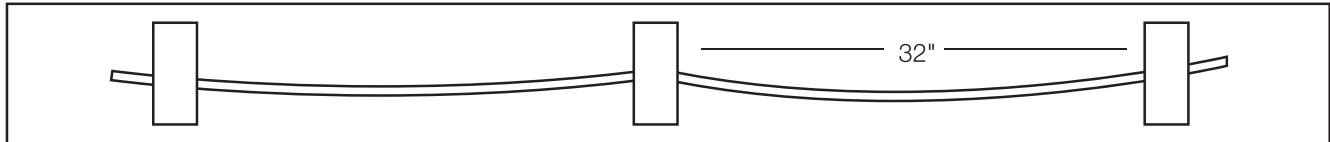
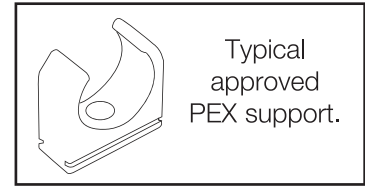

Concrete Installation SharkBite® PEX

The SharkBite® PEX tubing can be submerged in concrete but we recommend following these guidelines to ensure a long lasting, maintenance-free installation.

- Protect the tubing with non-metallic sleeves when entering or exiting the concrete slab. A larger diameter piece of SharkBite® PEX also works well in this application.
- Do not allow joints within the slab. Use a continuous length of SharkBite® PEX within the slab and be sure to check for leaks before pouring concrete.

Cross Linking Methods

Cross linking is a process that changes the chemical structure of high density polyethylene used to make PEX tubing, so that the polymer chains are connected with each other in a three-dimensional net by chemical bonds. PEX A, B, C and D are terms used to describe the different manufacturing methods used to produce PEX tubing. *Regardless of which manufacturing method is used, all PEX pipe meets the same standards for commercial and residential plumbing applications.*

Classification of Crosslinked Polyethylene

| | Typology | Method | Symbol |
|---|----------|--------------------------------|--------|
| A | Chemical | Peroxide cross linking | PEX-a |
| B | Chemical | Silane cross linking | PEX-b |
| C | Physical | Radiation cross linking (beta) | PEX-c |
| D | Chemical | Azocomponents cross linking | PEX-d |

Technical Data for SharkBite® PEX

{ SharkBite® PEX Tubing Marking: }

All SharkBite PEX Tubing is marked with:

TUBING LENGTH

0025 ft

MANUFACTURER

CASH ACME

OPTIONAL FOR OXYGEN BARRIER PIPE ONLY

TUBING SIZE & IDENTIFICATION

02 BARRIER

TUBING SIZE & IDENTIFICATION

1/2" SDR9 PEX5006 160PSI@73F - 100PSI@180F

MANUFACTURING LOCATION & DATE

C1 WG 6.12.14=16:00

CODE EVALUATION

CSA B137.5 ANSI/AWWA C904 ASTM F876/877 (ASTM F1807, ASTM F2098, ASSE1061)

Technical Data for SharkBite® PEX (cont'd)

{ Certifications: }

The SharkBite® PEX tubing is design certified to ASTM F-876, F-877, CSA B137.5 standards, and is listed to the NSF standards 14 and CSA B137.5 standards for use in potable water systems.

{ Maximum Working Pressure }

160psi @ 73.4°F (23°C)

100psi @ 180°F (80°C)

80psi @ 200°F (93°C)

{ Thermal Expansion: }

Since SharkBite® PEX tubing will expand and contract during temperature changes, please allow slack when running the tube through the building. SharkBite® PEX will expand and contract at a rate of approximately 1" per 100 feet of tubing for each 10°F change in temperature (see equation below). We recommend that offsets and expansion loops be used as ways to compensate for expansion and contraction. The change of pipe length due to temperature increase can be calculated as follows:

$$\Delta L = \alpha(L \cdot \Delta T)$$

where: ΔL = change of length (inches)

ΔT = change of temperature (°F)

L = original pipe length (feet)

α = coefficient of linear expansion = (8 x 10⁻⁵ @ 68°F)

Example:

$$\Delta T = 10^\circ\text{F} \quad L = 100' \quad \Delta L = 0.08''$$

{ Expansion/Contraction Loop Methods }

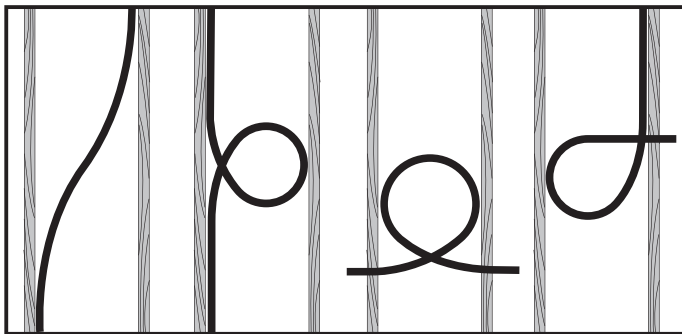

{ SharkBite® PEX Tubing Dimensions, Bend Radius and Fluid Capacity }

| Nominal Diameter | OD inches | ID inches | Bend Radius | Fluid Cap 100'/Gals |
|------------------|-----------|-----------|-------------|---------------------|
| 3/8" | 0.5 | 0.35 | 4" | 0.53 |
| 1/2" | 0.625 | 0.475 | 5" | 0.96 |
| 3/4" | 0.875 | 0.671 | 7" | 1.9 |
| 1" | 1.125 | 0.885 | 10" | 3.1 |

{ Pressure Loss Data: }

| Flow Rate GPM | Pressure Loss psi/100 ft of pipe | | | |
|---------------|----------------------------------|--------|--------|--------|
| | 3/8" | 1/2" | 3/4" | 1" |
| 0.2 | 0.427 | 0.099 | 0.019 | 0.006 |
| 0.3 | 0.880 | 0.204 | 0.039 | 0.012 |
| 0.4 | 1.470 | 0.341 | 0.065 | 0.019 |
| 0.5 | 2.189 | 0.508 | 0.097 | 0.029 |
| 0.6 | 3.032 | 0.703 | 0.135 | 0.040 |
| 0.7 | 3.993 | 0.926 | 0.177 | 0.053 |
| 0.8 | 5.069 | 1.175 | 0.225 | 0.067 |
| 0.9 | 6.258 | 1.450 | 0.278 | 0.082 |
| 1 | 7.555 | 1.751 | 0.335 | 0.099 |
| 1.1 | 8.960 | 2.076 | 0.397 | 0.118 |
| 1.2 | 10.470 | 2.425 | 0.464 | 0.138 |
| 1.3 | 12.080 | 2.799 | 0.535 | 0.159 |
| 1.4 | 13.800 | 3.195 | 0.611 | 0.181 |
| 1.5 | 15.610 | 3.615 | 0.691 | 0.205 |
| 1.6 | 17.520 | 4.058 | 0.776 | 0.230 |
| 1.7 | 19.530 | 4.523 | 0.865 | 0.256 |
| 1.8 | 21.640 | 5.010 | 0.958 | 0.284 |
| 1.9 | 23.840 | 5.519 | 1.055 | 0.313 |
| 2 | 26.140 | 6.050 | 1.157 | 0.343 |
| 2.5 | 39.000 | 9.024 | 1.724 | 0.511 |
| 3 | 54.100 | 12.510 | 2.390 | 0.708 |
| 3.5 | 71.360 | 16.500 | 3.150 | 0.933 |
| 4 | | 20.970 | 4.002 | 1.185 |
| 4.5 | | 25.900 | 4.943 | 1.463 |
| 5 | | 31.300 | 5.972 | 1.768 |
| 6 | | 43.440 | 8.284 | 2.451 |
| 7 | | | 10.930 | 3.232 |
| 8 | | | 13.890 | 4.108 |
| 9 | | | 17.170 | 5.076 |
| 10 | | | 20.750 | 6.134 |
| 11 | | | 24.630 | 7.281 |
| 12 | | | 28.810 | 8.514 |
| 13 | | | | 9.832 |
| 14 | | | | 11.240 |
| 15 | | | | 12.720 |

Policies & Warranty

Return Goods Policy

Restocking charges and items returned for credit:

- New Standard Catalog Items - 20% restocking charged if returned for credit only. For items ordered in error, the charge will be reduced to 10% if replacement items are purchased.
- Special Order Items (products with special modifications) - 25% minimum to 50% maximum restocking charge, depending on modifications (consult factory).

All restocking charges are based on F.O.B. Cullman, Alabama and products being new (never having been installed in a line). We do not accept any valves which have been used. Prior to return of product, an R.G.A. number must be assigned by a customer service representative. This number should be referenced on the outside of the carton and on all related paperwork. Items should be returned prepaid to 2400 7th Avenue SW, Cullman, Alabama, 35055, marked "Attn: Returns Department." Any information or correspondence may be sent with the product or mailed separately.

A. Reliance Worldwide Corporation, the Company, warrants the following products - SharkBite® PEX Tubing, SharkBite® Push-Fit Fittings, SharkBite® Brass PEX Barbed Fittings, SharkBite® Copper PEX Manifolds and other SharkBite® Accessories - to be free of defects in material and workmanship for the time periods shown below and when used and installed in accordance with the requirements set forth below.

1. SharkBite® PEX Tubing cross-linked polyethylene (non-barrier & barrier PEX) pipe for a period of twenty-five (25) years from the date of manufacture.
2. SharkBite® Push-Fit Fittings brass push fit fitting for a period of twenty-five (25) years from the date of manufacture.
3. SharkBite® Brass PEX Barbed-Fittings and SharkBite® Copper PEX Manifolds for a period of sixty (60) months from the date of manufacture.
4. All other valves and accessories sold under Reliance Worldwide Corporation's brand names of the SharkBite® PEX and / or SharkBite® Connection System for a period of twenty-four (24) months from the date of manufacture.

SharkBite® products shall be installed in accordance with all applicable plumbing, heating and mechanical codes and in accordance with any local, state or federal requirements.

Reliance Worldwide Corporation's obligation will be to repair or replace, at its discretion, any of the products covered under this limited warranty when the materials used to produce the product or the workmanship of the manufacturing process are proven to be defective.

B. In the event of a system malfunction or leak caused by defective warranted products (and not by improper installation or usage, incorrect handling procedures or by jobsite or installation damage), a reasonable pre-approved amount will be allowed for repair materials and repair labor. In the event of a leak occurring in the factory manifold, please contact Reliance Worldwide Corporation. Note that Reliance Worldwide Corporation limits its warranty to its tubing, valves and accessories, fittings and manifolds. Reliance Worldwide Corporation does not warrant the connection. The integrity of the connection is the sole responsibility of the installer.

C. To qualify for a warranty remedy under paragraph B, you must contact Reliance Worldwide Corporation in advance and receive written authorization for this remedy from an authorized Reliance Worldwide Corporation representative. Reliance Worldwide Corporation will not consider expenses for repair materials, labor and / or freight unless authorized in advance and in writing.

D. To qualify for the warranty described above, you must:

1. Use construction techniques in compliance with applicable plumbing, heating and mechanical codes to install our products, as specified in our current design and installation guidelines and technical notes. This shall include field pressure testing prior to concealing with concrete or by other means.
2. Install and use Reliance Worldwide Corporation's SharkBite® PEX Tubing and Reliance Worldwide Corporation's SharkBite® Connection System products according to all guidelines and manuals published by Reliance Worldwide Corporation. It is expressly understood that failure as a result of any freezing fluids within the pipes does not constitute a defect in material or workmanship and shall not be covered by this warranty.

3. Install and use Reliance Worldwide Corporation SharkBite® PEX Tubing and Reliance Worldwide Corporation SharkBite® Connection System products in a system that will not operate at temperatures or at pressures that exceed the printed rating on the tubing.
4. Install and use all warranted Reliance Worldwide Corporation SharkBite® product in compliance with any applicable local building, plumbing and mechanical codes.

E. Evidence of tampering, mishandling, neglect, accidental damage, freeze damage or unauthorized repairs that cause damage to Reliance Worldwide Corporation's SharkBite® warranted products void any warranty coverage of those particular products. The terms of this warranty specifically exclude all field connections. Reliance Worldwide Corporation, in its sole discretion, can decide whether the warranty will be honored or is void.

F. Although Reliance Worldwide Corporation provides a plumbing system to facilitate a complete installation; other manufacturer's tubing and/or fittings may be installed in any given installation provided manufacturing of the tubing and/or fittings demonstrates compliance with the applicable ASTM standards, and the product has been certified by a recognized third-party testing agency. The Reliance Worldwide Corporation product in the given installation will continue to be covered under this warranty. **NOTE:** Reliance Worldwide Corporation will be responsible only for proven defects in material or workmanship in Reliance Worldwide Corporation products. Problems in products manufactured by another company should be reported to that manufacturer.

G. Disclaimer of Warranty. THE EXPRESS WARRANTY SET FORTH HEREIN IS THE ONLY WARRANTY GIVEN BY Reliance Worldwide Corporation WITH RESPECT TO THE PRODUCTS LISTED IN PARAGRAPH A. Reliance Worldwide Corporation MAKES NO OTHER WARRANTIES, EXPRESS OR IMPLIED, AND HEREBY SPECIFICALLY DISCLAIMS ALL OTHER WARRANTIES, EXPRESS OR IMPLIED, INCLUDING BUT NOT LIMITED TO THE IMPLIED WARRANTIES OF MERCHANTABILITY AND FITNESS FOR A PARTICULAR PURPOSE.

H. Limitation of Remedy and Liability. The remedy described above shall constitute the sole and exclusive remedy for breach of warranty, and, apart from that remedy, Reliance Worldwide Corporation shall not be responsible for any incidental, special or consequential damages, including without limitation, lost profits or the cost of repairing or replacing other property which is damaged if these warranted products do not work properly, other costs resulting from labor charges, delays, vandalism, negligence, fouling caused by foreign material, damage from adverse water conditions, adverse chemical environments, or any other circumstances over which Reliance Worldwide Corporation has no control. This limitation applies even if Reliance Worldwide Corporation could have foreseen or has been advised of the possibility of these damages. This warranty shall be invalidated by any abuse, misuse, misapplication or improper installation of the product. Proof of purchase is required to validate the warranty period.

Some states do not allow limitations on how long an implied warranty lasts, and some states do not allow the exclusion or limitation of incidental or consequential damages. Therefore, the above limitations may not apply to you. This Limited Warranty gives you specific legal rights, and you may have other rights that vary from state to state. You should consult applicable state laws to determine your rights. **SO FAR AS IS CONSISTENT WITH APPLICABLE STATE LAW, ANY IMPLIED WARRANTIES THAT MAY NOT BE DISCLAIMED, INCLUDING THE IMPLIED WARRANTIES OF MERCHANTABILITY AND FITNESS FOR A PARTICULAR PURPOSE, ARE LIMITED IN DURATION TO ONE YEAR FROM THE DATE OF ORIGINAL SHIPMENT BASED ON PROOF OF PURCHASE, OR, IF NOT AVAILABLE, FROM THE DATE OF MANUFACTURE.**

I. RETURNED GOODS - CREDIT: No products shall be returned without authorization. Any credit issued will be at the price originally invoiced, less handling charges, based on the costs of reconditioning, boxing, etc. Obsolete or made to special order products are not returnable.

NOTE: Prices and terms are subject to change without notice and supersede all previous quotations. Reliance Worldwide Corporation reserves the right to change or modify product design or construction without prior notice and without incurring any obligation to make such changes and modifications on products previously sold.

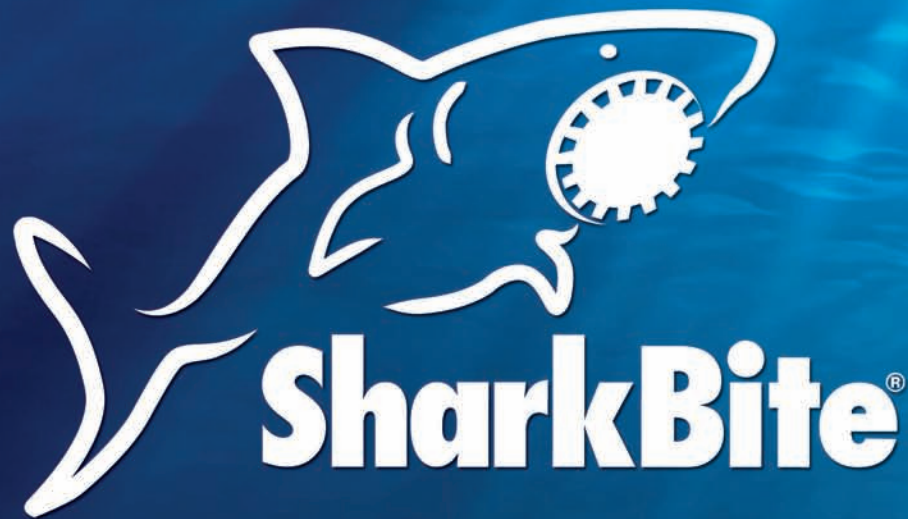

2727 Paces Ferry Road
Building Two Suite 1800
Atlanta, GA 30339

Tel: 1-877-700-4242
Fax: 1-877-700-4280

www.sharkbite.com

A Division of the Reliance Worldwide Corporation

