



End Table

Free Plans to build a simple End Table



MATERIALS & TOOLS

TOOLS:

- Jigsaw, table saw, miter saw, or hand saw
- Brad nailer
- Drill
- Pocket hole jig
- Tapering jig
- Countersink bit for drill
- Pencil, ruler, square
- Tape measure
- Sander
- Iron for edge banding
- Edge banding trimmer or craft knife

MATERIALS:

- 1 - 1/4" brad nails
- 1 - 1/4" pocket hole screws
- 1-1/4" screws
- 1 drawer pull
- 7/8" & 2" Edge banding, optional
- Wood glue
- Sandpaper (100, 150, 220 grits)
- Finishing supplies (primer & paint, or stain, sealer)
- Paste wax

Lumber:

- One - 4' x 4' x 3/4" PureBond plywood project panel (Maple was used in the example)

Cut List:

- Eight - 3/4" PureBond plywood project panel at 1-3/4" x 19-1/4" - Legs
- Four - 3/4" PureBond plywood project panel at 1-1/2" x 11-1/2" - Side Frames
- Two - 3/4" PureBond plywood project panel at 8-1/8" x 11-1/2" - Side Panels
- Four - 3/4" PureBond plywood project panel at 1-1/2" x 14" - Back Frame & Front Stretchers
- One - 3/4" PureBond plywood project panel at 8-1/8" x 14" - Back Panel
- One - 3/4" PureBond plywood project panel at 15" x 18" - Top
- One - 3/4" PureBond plywood project panel at 10-3/4" x 11-1/2" - Drawer Bottom
- Two - 3/4" PureBond plywood project panel at 7" x 11-1/2" - Drawer Front & Back
- Two - 3/4" PureBond plywood project panel at 7" x 12-1/4" - Drawer Sides
- Two - 3/4" PureBond plywood project panel at 3/4" x 12" - Drawer Runners
- One - 3/4" PureBond plywood project panel at 7-7/8" x 13-3/4" - Drawer Front



FEATURING
PureBond[®]
FORMALDEHYDE-FREE TECHNOLOGY



STEP 1

Notes: Edge banding to cover the exposed edges of the plywood is optional and will be applied before assembly.

Cut the pieces for the legs. There will be eight pieces cut, and they will be laminated together in pairs to form the leg. Spread glue on the face of one piece then layer the next piece on top. Wiggle it a little to create suction then secure together with 1-1/4" brad nails. When dry, cut the taper using the tapering jig on the table saw. If using edge banding, apply it to the exposed edges of the legs then trim.

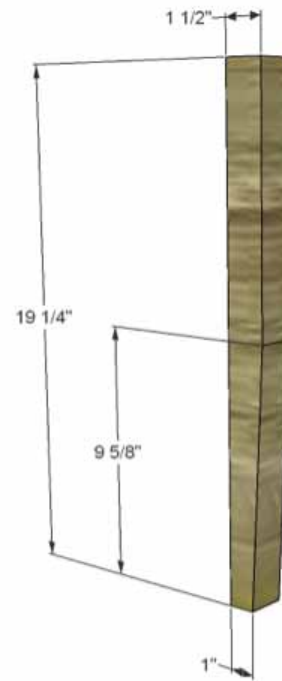

STEP 2

Cut the pieces for the side frames and the panels. With the pocket hole jig set for 3/4" material, drill pocket holes in each end of the frame pieces as well as the two longer edges of the side panels. If using edge banding, apply it to one edge of each frame piece. This edge will face to the outside.

Attach the frame pieces to the panels with the pocket holes facing away from the panels using glue and 1-1/4" pocket hole screws. The back face of the panel will be flush with the back edge of the frame pieces.

Attach the panel assemblies to the legs (with the tapers facing to the inside) using glue and 1-1/4" pocket hole screws through the frame pieces.

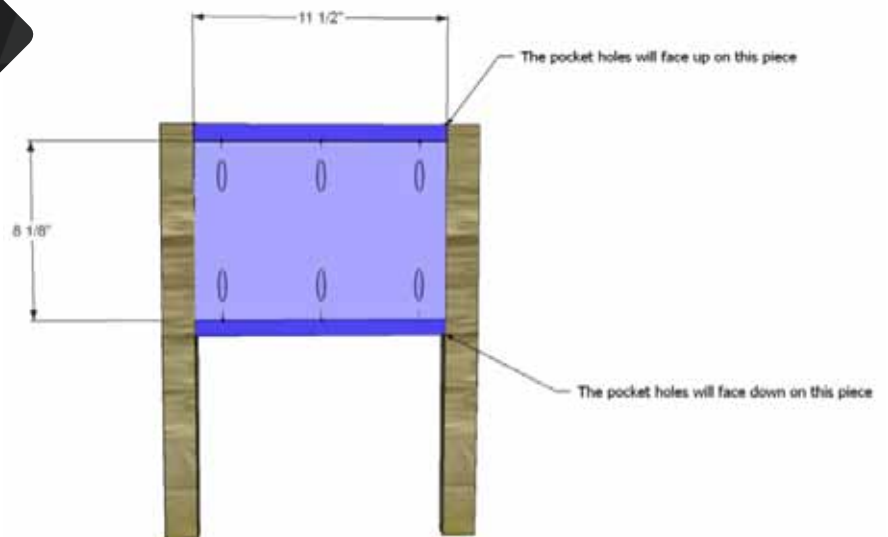



STEP 3

Cut the pieces for the back frame and panels. Drill pocket holes in each end of the frame pieces as well as two long edges of the panel. If using edge banding, apply it to one edge of each frame piece. This edge will face to the outside. Attach the frame pieces to the panel with the pocket holes facing away from the panel using glue and 1-1/4" pocket hole screws.

The back face of the panel will be flush with the back edge of the frame pieces. Attach the panel assemblies to the legs using glue and 1-1/4" pocket hole screws through the frame pieces.

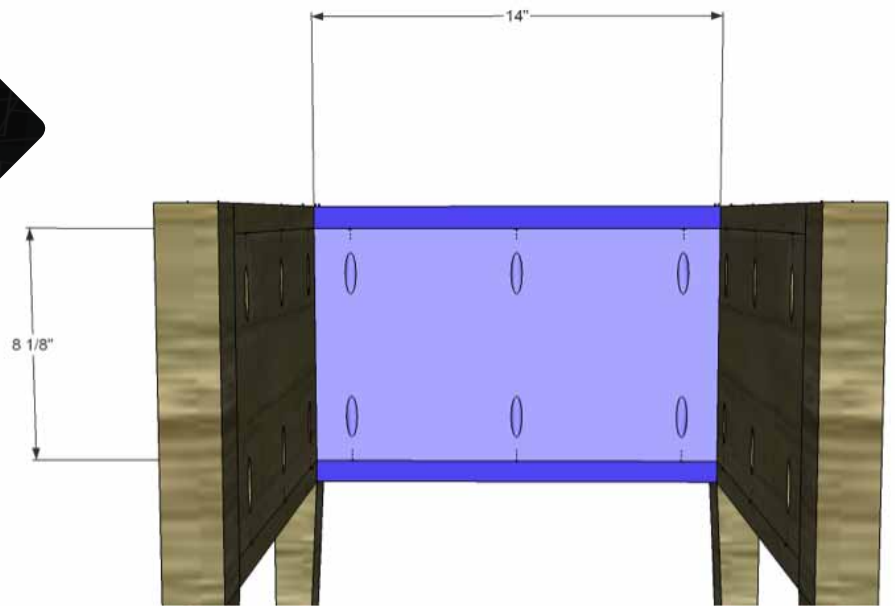

STEP 4

Cut the pieces for the front stretchers and drill pocket holes at each end. Position the stretchers so that the pocket holes on the upper stretcher face up and face down on the lower stretcher. Secure to the legs as shown using glue and 1-1/4" pocket hole screws.

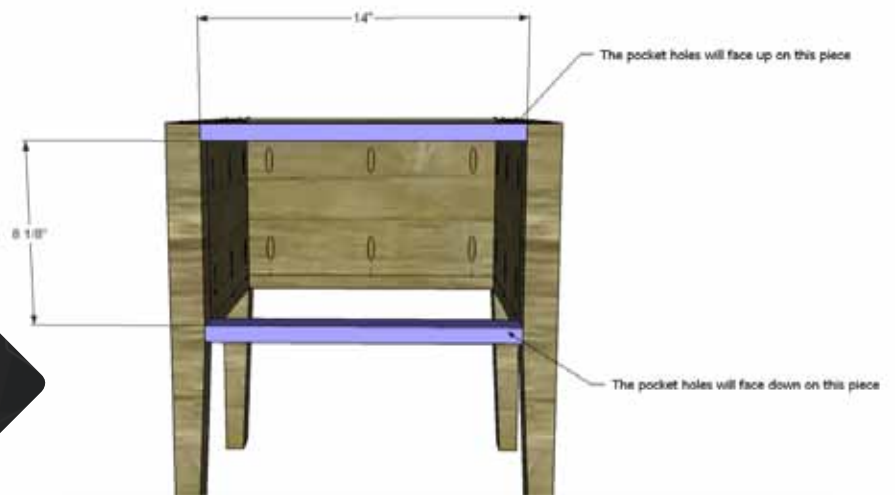

STEP 5

Cut the piece for the top. Round off the edges using a jigsaw or a sander, if desired, then apply edge banding to the exposed edges. The front and sides of the top will overhang by 1/2". Secure the top using glue and 1-1/4" brad nails through the top into the frame pieces and stretchers.

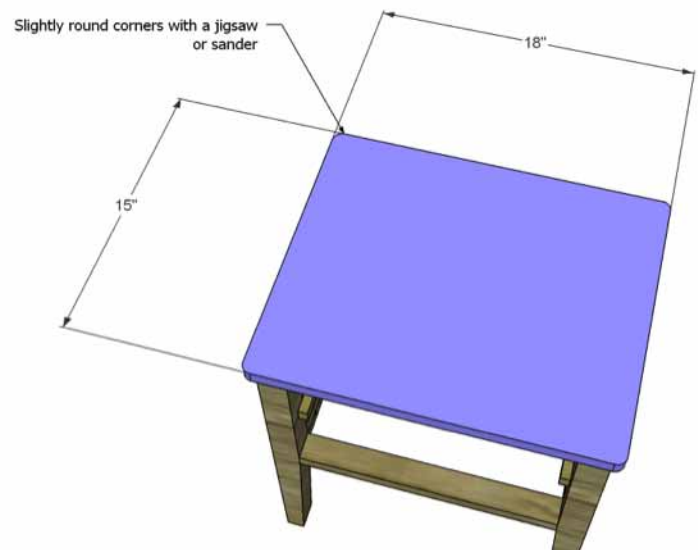



STEP 6

Cut the pieces for the drawer box. Drill pocket holes in each end of the front and back pieces as well as all four edges of the bottom. Secure the front and back to the bottom using glue and 1-1/4" pocket hole screws.

Cut the dado in the side pieces using a router and a dado bit or by using a dado stack on the table saw. The dados will be cut 7/8" wide by 1/2" deep. Attach the side pieces to the drawer box using glue and 1-1/4" pocket hole screws.

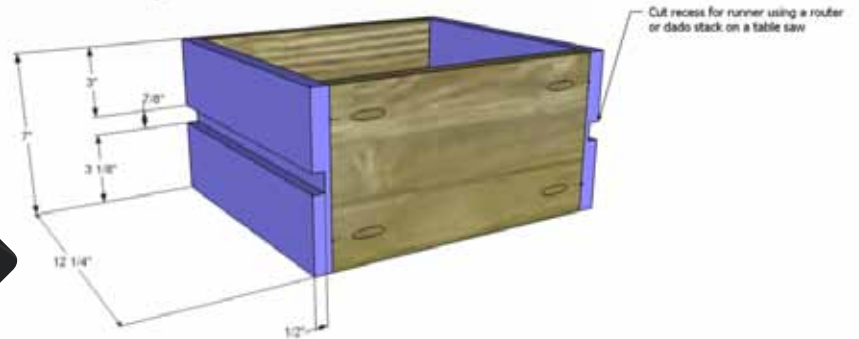
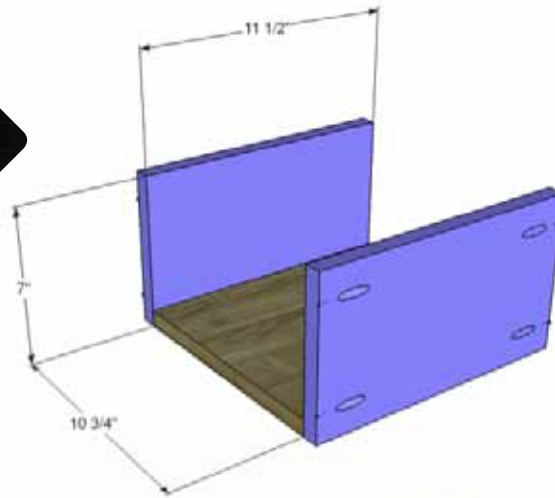

STEP 7

Cut the pieces for the drawer runners. Locate them in the cabinet so that the drawer box clears the lower stretcher by 1/8" and positioned 3/4" back from the front face of the legs to allow for the drawer front.

Drill countersunk holes in each piece. Secure the runners using glue and countersunk 1-1/4" screws. Apply a coat of paste wax to the runners and the dados on the drawer box to help the box slide smoothly.

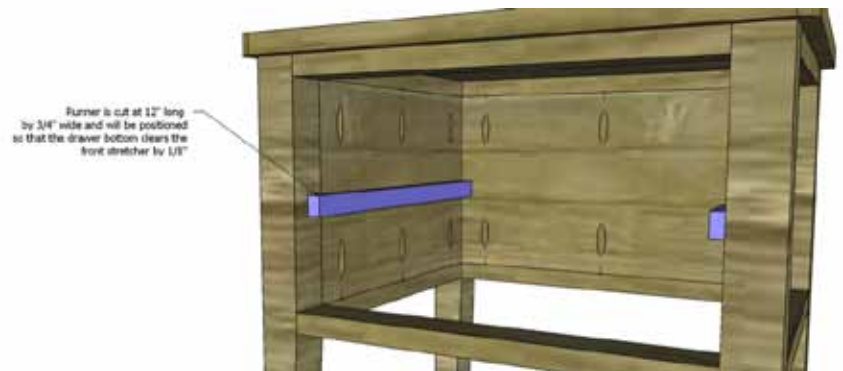

STEP 8

Cut the piece for the drawer front. Mark the position for the drawer pull and drill the holes. Shim the drawer front in the opening - there will be a 1/8" gap around all sides - then drive screws through the holes for the drawer pulls into the drawer box. Open the drawer, and secure the drawer front using countersunk 1-1/4" screws from the inside. Remove the screws from the holes for the drawer pull then finish drilling the holes. Install the drawer pull.

